

DESCRIPTION

MEGAFIRE is an Automatic Fire Curtain that in the case of fire, limits and controls the fire, with classification EI₁60 and EI₂120.

The curtain is composed of fibreglass fabric with intumescent coating seamed with reinforced steel wire and fixed to a steel roller with 89 mm of diameter. The headbox and sideguides are manufactured in Galvanized steel.

All the system is driven by a 230 V tubular motor with Special Gravity Fail-Safe System.

The control panel for automatic curtains (CBM), with a nominal input voltage of 115 V or 220 V and output voltage of 230 V.

Uninterruptible Power Supply (UPS System) exists in all control panels.

Tested in accordance with EN 1634-1 and classified in accordance with EN 13501-2, CE Marking according to EN 16034 standard.

CLASSIFICATION

EI₁60

EI₂120



megafire

OPERATION

The system can be activated by a SHEV, fire alarm contact, internal fire and smoke detection devices, or manual emergency buttons. In the event of a fire, the Control Panel (CBM), receives the signal alarm, and the automatic curtain deploys automatically, with the controlled and safe constant speed of descent even following total power loss on all curtains. If there is a false alarm the curtains return to stand-by position automatically after reset of alarm from the main Fire Management Systems. In case of main power loss, the curtain will remain fully retracted thanks to the battery backup system.

FABRIC

The curtain is composed by five layers. Two outer layers in fiberglass cloth plus intumescent "TRIAMF-1", two intermediate layers in fiberglass cloth plus intumescent reinforced with wire "TRIA MF-3", plus a central layer of Silica with aluminium on both sides of "TRIA MF-2".

HEADBOX

Galvanized Steel headbox 1.2 mm thickness with different possibilities to adapt to different architectural spaces, and maintenance requirements. Dimensions of the headbox vary depending on the width and height of the curtain.

SIDE GUIDES

Galvanized Steel from 1,5 to 3 mm thickness.

ROLLER

Galvanized Steel of 3 mm thickness and 89 mm diameter.

ELECTRIC MOTOR

Tubular motor: 230 V
Maximum power: 435 W / 120 Nm
Maximum current: 1.9 A
Average linear speed: 0.11 m/s

CBM CONTROL PANEL

Receives the signal alarm from the Fire Management System and controls the movement of curtains. Visual and acoustic alert system.
Dimensions (W x H x D): from 300 x 230 x 140 mm
Input: 115 or 220 V 50Hz
Output: 230 V
Battery: 2 x 12 V 7 Ah rechargeable

OPTIONAL EXTRAS

RAL coating: headbox and side guides.
Stainless steel elements: headbox, side guides, screws, rivets.
Escape button: pushing this button the curtain goes up and the user can escape through the opening, the curtain deploys 30s later automatically.
Emergency button: pushing this button the curtain deploys immediately.

Note: other requirements and customized solutions on demand.

HEADBOX

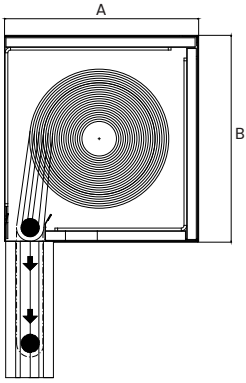

SINGLE ROLLER
A: 375-775 mm
B: 400-800 mm

SIDE GUIDES

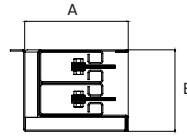

**SCREW SIDE GUIDES
STANDARD**
A: 170 mm
B: 130 mm

HEADBOX INSTALLATION

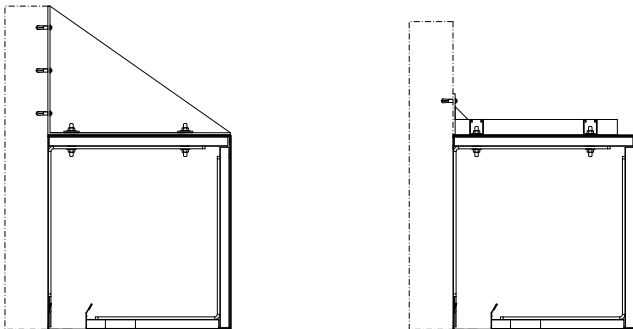

SIDE GUIDES INSTALLATION

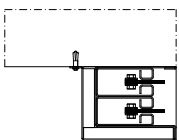

SIDE WALL

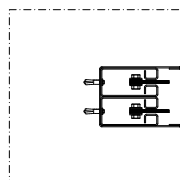

HIDDEN

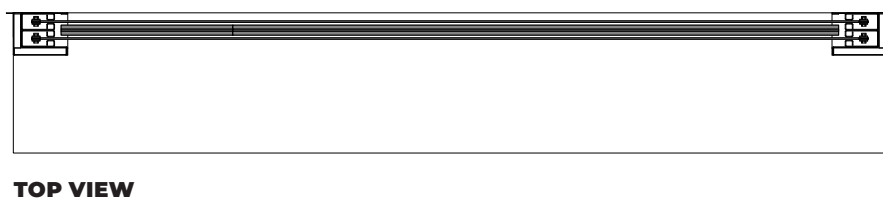
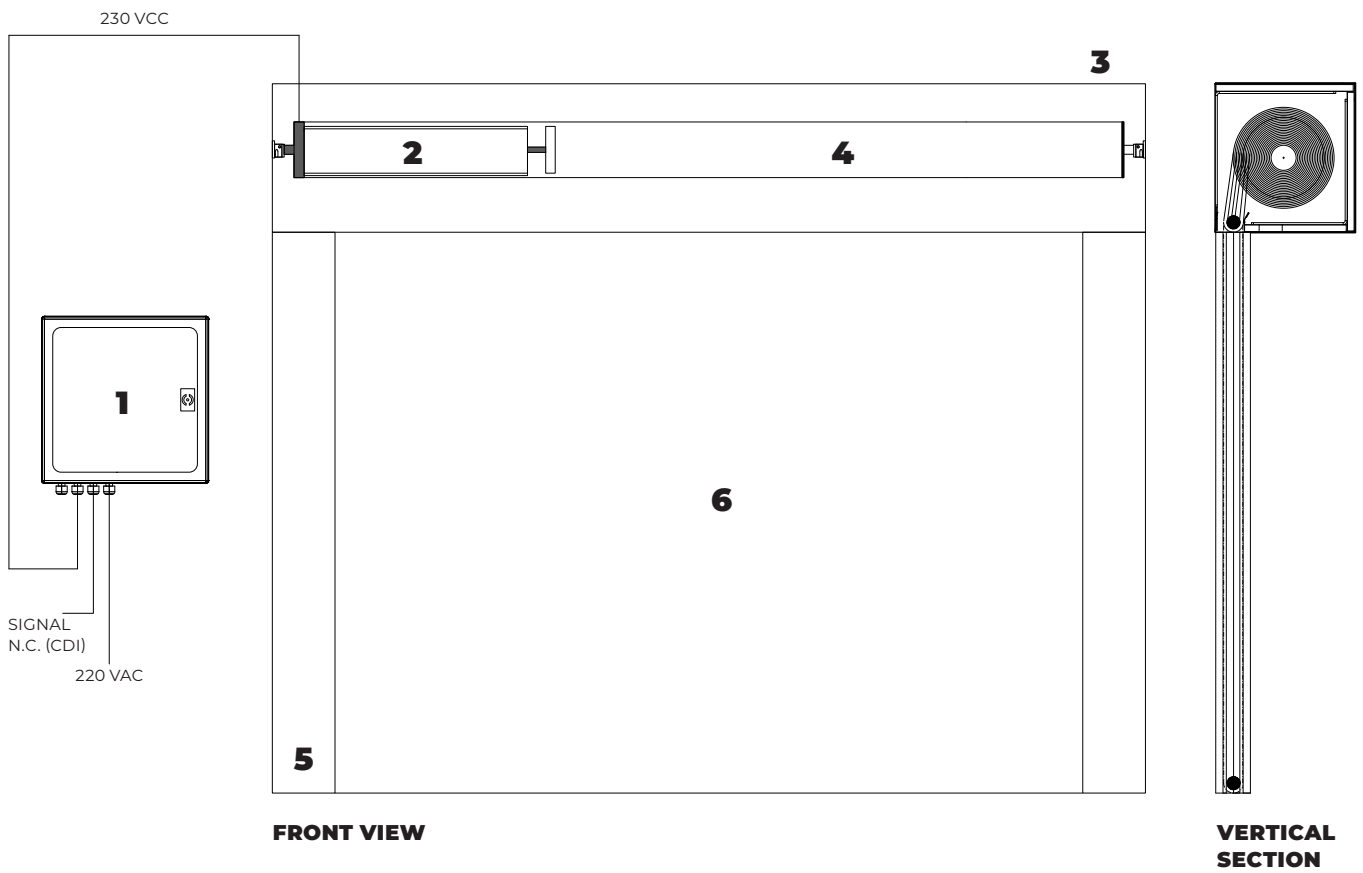

1. control panel CBM
2. TRIA motor 230 V
3. galvanized steel headbox
4. galvanized steel roller
5. galvanized steel side guides
6. fire resistant fabric