

PRODUCT FEATURES

DELTA is a double flap smoke vent suitable for the removal of large quantities of warm air and / or smoke from a building within a short period of time, daily ventilation and natural lighting. Suitable for utilization on various kerbs and domes.

The vents are manufactured according to ISO 9001 quality control standards and comply with the European requirements for NSHE according to EN 12101-2. Endurance tests with 10,000 opening and closing cycles have proven its robust and functional design. The vents are formed from high quality corrosion resistant aluminium to ensure low maintenance requirements and watertightness.

Various methods of operation using pneumatic or electric actuators are available. Available on large dimensions, up to 2500 x 3500 mm (width x length).

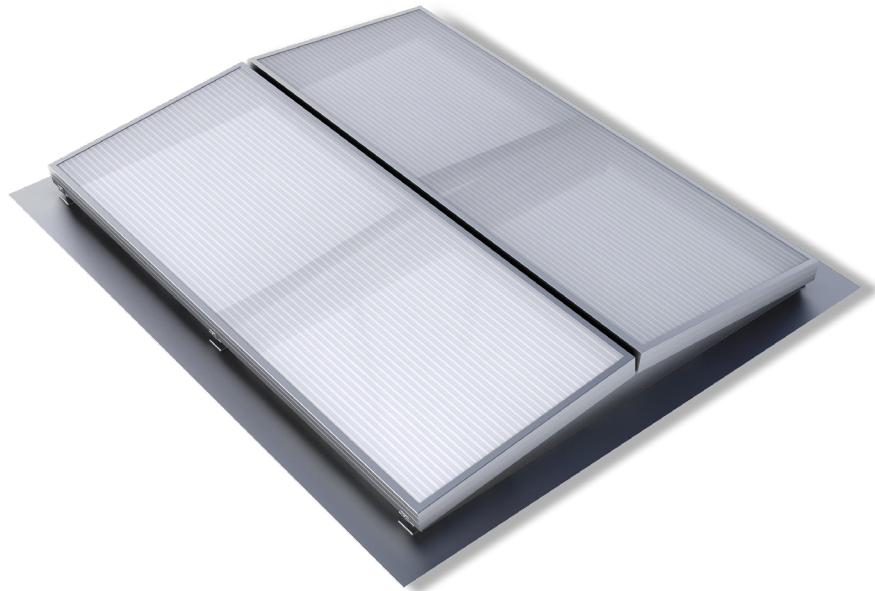

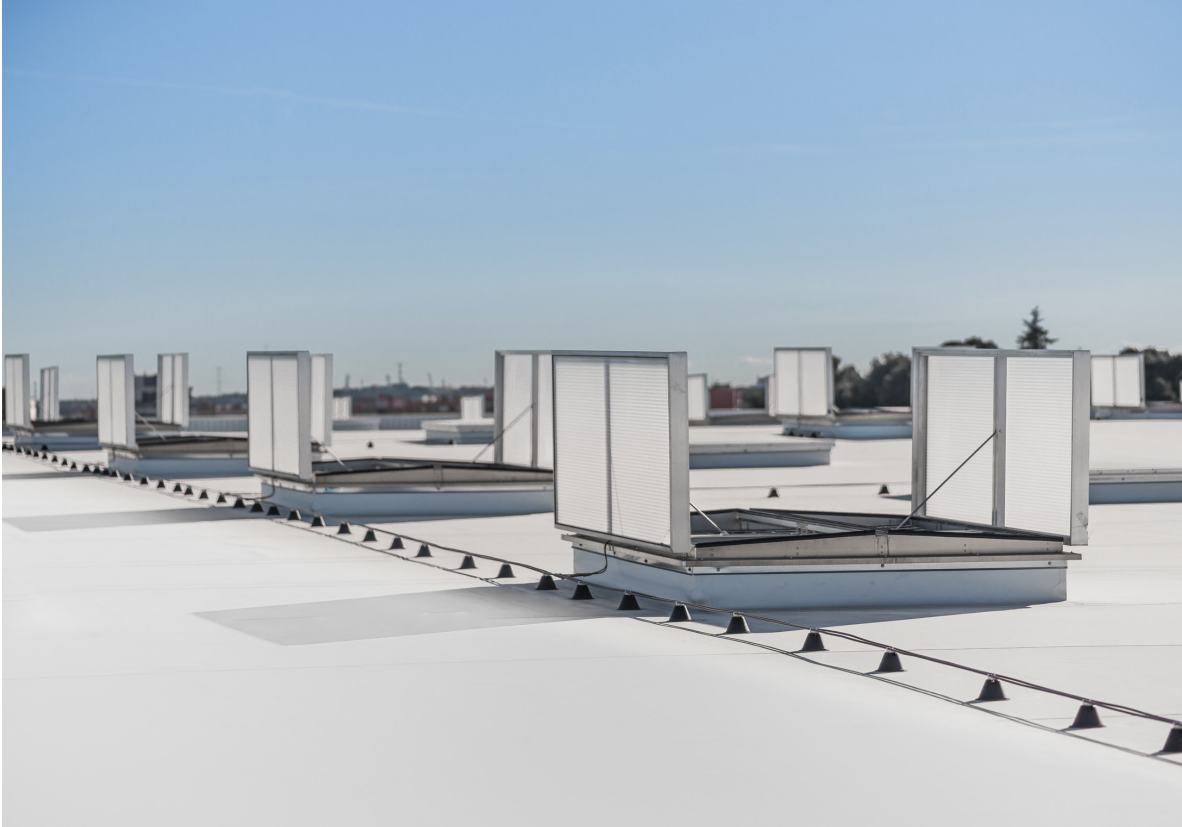

delta

TYPICAL APPLICATIONS

May be installed either onto roofs or into barrel vault daylighting systems. Particularly suitable for warehouses, logistics centres, production environments and industries.

MATERIALS

Tempered aluminium, sea water and corrosion resistant (EN AW 5754). Corrosion resistant bearings. Sealant applied so that there is no freezing, enabling the equipment to have low air permeability at the same time.

Note: aluminum is supplied untreated as standard. Possibility of being supplied with electrostatic painting (in any RAL color).

DIMENSIONS

Roof opening width: 1000 - 2500 mm.
Roof opening length: 1000 - 3500 mm.

OPENING ANGLE

Individual adjustable from 0° up to 90°.

CONTROLS NATURAL VENTILATION

P2: double pipe compressed air operation.
M230V: electric motor.

CONTROLS FIRE VENTILATION

P2F: double pipe compressed air operation with fire function.
M24V: electric motor.

WEIGHT

Depends on dimensions and type of infill.

OPTIONS

Custom dimensions.
 Powder-coated design (any RAL colour).
 Bird or insect mesh/ Anti-fall grid 1200 J.

REGULATIONS

The system has been tested and is certified in accordance with EN 12101-2.
 Tested in accordance with the Directive 2014/34/EU, DELTA is ATEX certified equipment.

FLAPS

- AL** Single aluminium.
- AL ISO** Thermally insulated aluminium.
- PC16** Polycarbonate 16mm, clear or opal.
- PC25** Polycarbonate 25mm, clear or opal.
- PC32** Polycarbonate 32mm, clear or opal.
- TB** Thermal break in the aluminium profiles. Available for flaps of AL ISO, PC25 mm, PC32 mm.

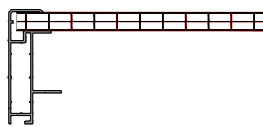

PC16

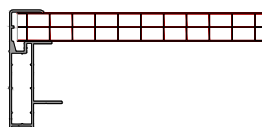

PC25

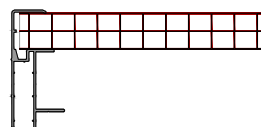

PC32

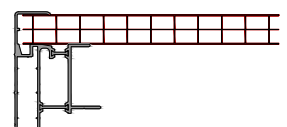

PC25 TB

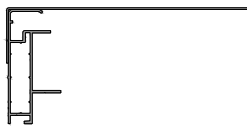

AL

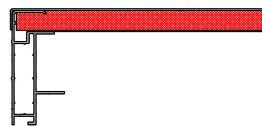

AL ISO 20

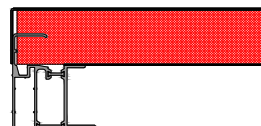

TB AL ISO 50

BASES

Single aluminium.
 Double wall aluminium with insulation.
 Double wall aluminium with insulation and TB, thermal break in the aluminium base.

Note: other non-standard bases available upon request.

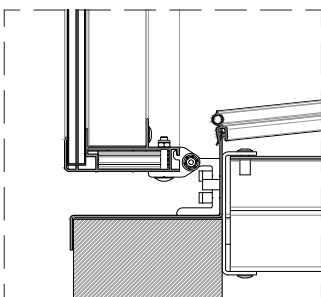

DETAIL 01
single aluminium

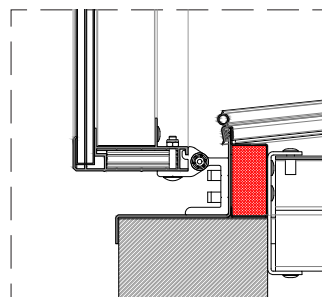

DETAIL 02
double wall aluminium with insulation

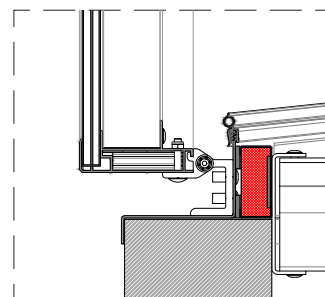

DETAIL 03
double wall aluminium with insulation and TB, thermal break in the aluminium base

FLANGES

- S1** Flange for single glass.
- S2** Flange for double glass.
- S3** Flange for roofs, 45° bended.
- S4** Flange for roofs and facades.
- S5** Flange for upstand, 90° bended downwards.
- S6** Flange 90° bended upwards.
- SLS** Flange for skylight connection, for different polycarbonate thicknesses.
- SC** Flange for connection with other flange (vents connection). Male or female connection.
- SCM** Flange for male connection.
- SCF** Flange for female connection

Note: custom flange design and insulated flanges upon request.

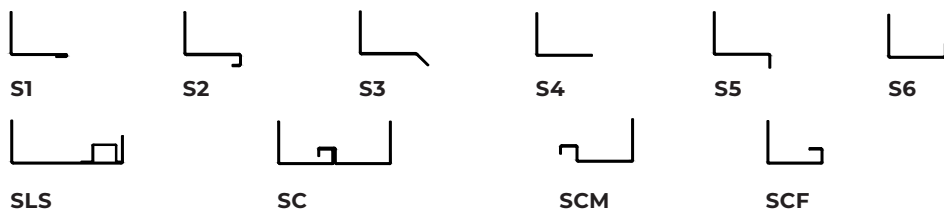

STANDARD INTERIOR DIMENSIONS

TYPE	1010	1015	1020	1025	1030	1035	1510	1515	1520	1525	1530	1535
WIDTH (mm)	1000						1500					
LENGTH (mm)	1000	1500	2000	2500	3000	3500	1000	1500	2000	2500	3000	3500

TYPE	2010	2015	2020	2025	W2030	2035	2510	2515	2520	2525	2530	2535
WIDTH (mm)	2000						2500					
LENGTH (mm)	1000	1500	2000	2500	3000	3500	1000	1500	2000	2500	3000	3500

DRIVE SUPPORT

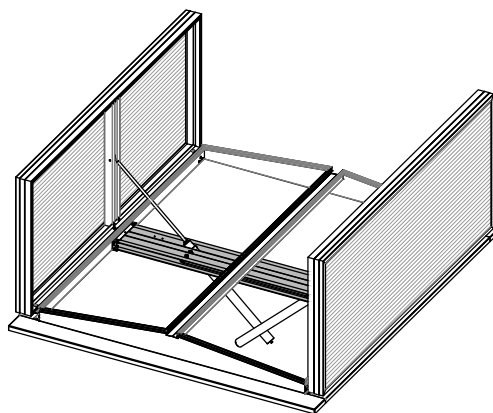

DOUBLE FLAP SYSTEM WITH SHORT CYLINDERS, DELTA-S

Deviating from the standard version, DELTA can also be designed with short cylinders. This variant is used when there is a risk that the cylinders could collide with the existing bottom pipe-work, beams or other objects on site.

The DELTA-S variant is available in sizes:

Width: 1200 up to 2300 mm.

Length: 1000 up to 3000 mm.

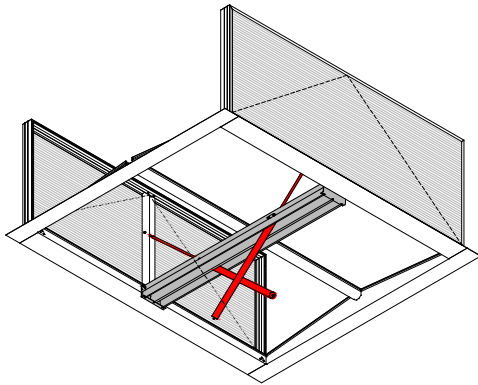

DELTA

Bottom Perspective View OPEN
opening system

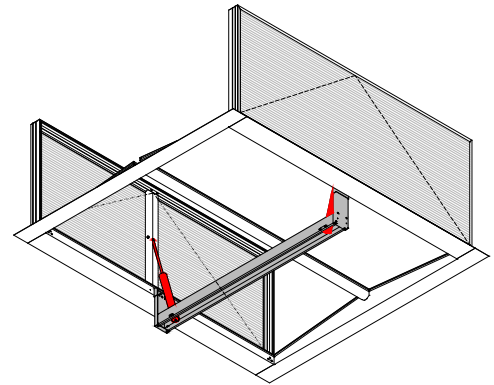

DELTA-S

Bottom Perspective View OPEN
opening system

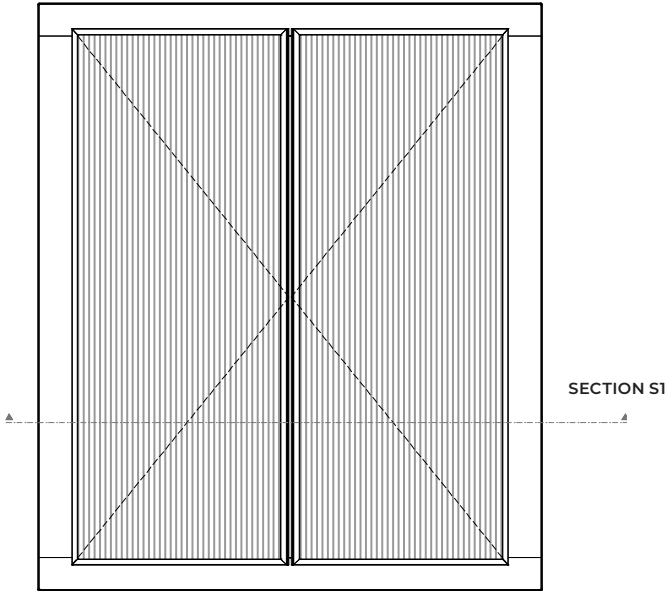

DIMENSION DRAWING FOR DELTA INSTALLATION

WIDTH	DRIVE	X	Y	Z
1000 - 1700	P2F - 575	427	660	162
	M24V - 575	427	630	-
1701 - 2500	P2F - 800	598	890	162
	M24V - 800	598	830	-

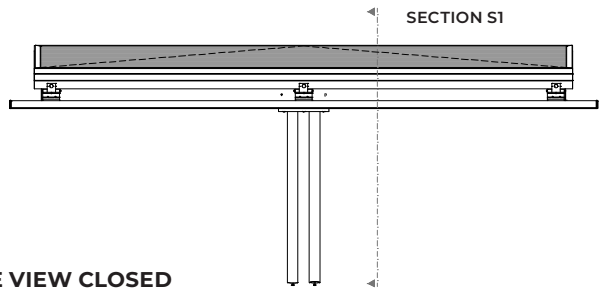

SIDE VIEW CLOSED

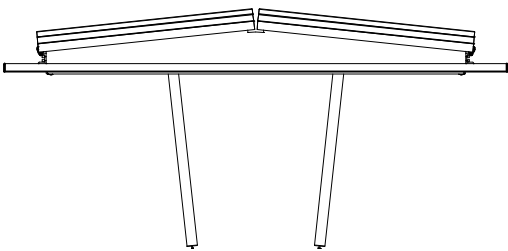

FRONT VIEW CLOSED

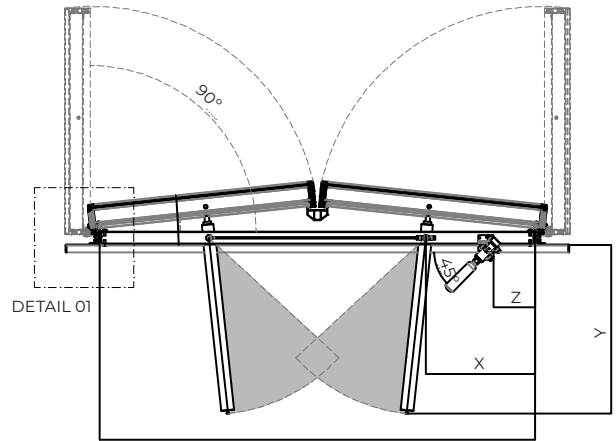

SECTION S1

WIDTH